

## MOBILE EXHIBIT EQUIPMENT

Show credentials



50 amp power supply



13' 4" minimum height clearance

20' x 50' display space (1,000 sq. ft.)

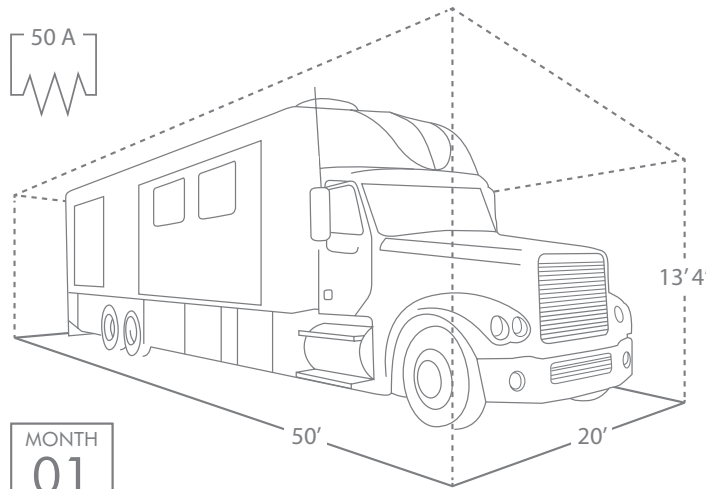

Fixed pre-show move-in date



Exhibitor List



Place aisle carpet to wheels



Guide demo at MPI 2009 World Education Conference

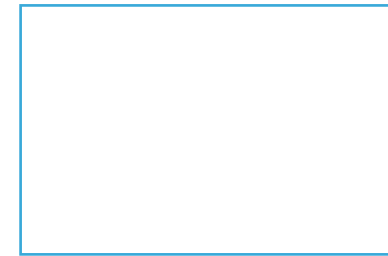

After-hours cocktail reception

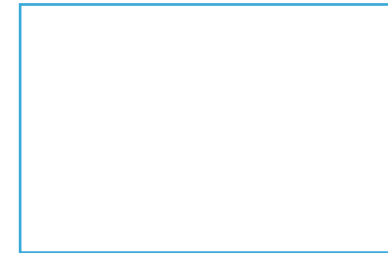

At 2009 ASAE Expo in Toronto

## MOTORCOACH CHECKLIST

The truck's presence at your event is meant to generate not just awareness but enthusiasm for your member service-oriented online buyers guide or e-news brief. It's also a powerful visual for drawing exhibitors and advertisers to see your digital publications as a new way to build relationships with your members. With two kiosks stationed alongside the truck, members and exhibitors can demo your digital publications live on the show floor. After the show floor closes, the truck becomes a conversation-starting backdrop for cocktail receptions and other VIP gatherings.

**CONTACT** Jim Cassella  
 MultiView Senior Vice President  
 office: 972-402-7060  
 cell: 972-839-2323  
 jcassella@multiview.com